

BLUE BOY
PAINT REJUVENATOR
Owner's Manual



Table of Contents

Introduction.....	3
Safety Precautions.....	4
Installation Instructions.....	4
Electrical Connections.....	5
Operating Instructions.....	6
Maintenance Procedures.....	6
Parts lists	7
Ordering Replacement Parts..	11



Introduction

About Us

www.MiraclePaint.com

Miracle Paint Rejuvenator recently celebrated its 75th Anniversary of producing quality specialty mixing solutions.

Fred A. Schletz, Miracle Paint's founder, invented the first shaker in 1932. His invention was designed to rejuvenate his stock of paint for his three paint stores so his inventory would not spoil. This timely invention not only helped Fred survive the depression years, the demand for his mixers became so great, that he sold the paint stores and started the Miracle Paint Rejuvenator company to produce mixers full time!

That commitment to innovation and quality engineering continues to this day with our most recent line roll out of heavy duty industrial mixers - Pacer Industrial Mixers. Whether your requirement is for Laboratory Mixers, Automotive Shakers, Architectural Paint Mixers, Shakers for Ink Preparation, Industrial Products Blenders or Tumbler and Debur Applications we have a heavy duty industrial mixer that meets your need!

Miracle Paint Rejuvenator's Blue Boy Mixers are heavy duty quality built machines that offer dependable operation throughout their lifetime.

The highly efficient, fast operating clamping system allows you to shake 1, 2, or 5 gallon steel or plastic pails up to 80 pounds without the use of adapters.

To take full advantage of your mixer's capabilities, you should understand its features and proper operation. Before operating mixer read this manual completely and save for future reference.

Machine Models

This manual includes instructions and replacement parts information for the MBB-5-C & MBB-5-C EXP models.

- 115/230V 60 Hz 1/2 HP mixer - 30 minute dial timer
- 115/230V 60 Hz 1/2 HP Explosion Proof Mixer (Class 1, Group D environment) - no timer



Safety Precautions

Follow these safety precautions when operating the Miracle Paint Rejuvenators Blue Boy Mixer.

Installation

1. Before operating the machine, read this Owner's manual carefully.
2. Ground the machine properly. Be sure to follow proper grounding and electrical procedures.
3. Avoid dangerous environments. Do not use the machine in a damp or wet environment.
4. Use the proper power source
 - Dial timer model: Plug cord into 110V outlet.
 - Explosion proof model: Must be installed by qualified electrician in compliance with the hazardous environment the mixing is taking place in (see page 5).
5. Avoid extension cords. To minimize the risk of circuit overload, or improper electrical grounding do not use extension cords.

Operation

6. Ensure the can being mixed is securely clamped.
7. Keep customers away from mixing area. Only trained personnel should operate the mixer.

Maintenance

8. Do not get the timer or wiring wet. Failure to do so could result in electric shock.
9. Clean all surfaces of the machine with soap and water. Do not use any solvent-based cleaners or thinners.
10. Disconnect machine from power source before cleaning or servicing mixer.
11. Be sure to maintain the mixer on a regular basis. Follow the maintenance procedures on page 6.

Installation Instructions

Machine must be anchored to floor. Use appropriate hardware.

When anchoring the mixer ordinary precaution should be taken to level the machine. Corner shims may be necessary before securing the mixer to floor.



Electrical Connection and Grounding Requirements



MBB-5-C

Your mixer **MUST BE PROPERLY GROUNDED**. If there is an electrical short circuit, grounding reduces the risk of electric shock.

The machine's power cord has a grounded plug. This plug must be inserted into an electrical outlet that is properly installed and grounded according to all local codes and ordinances.

If you must repair or replace the power cord or plug, do not connect the grounding wire to either flat-blade terminal. The wire with insulation having an outer surface that is green (with or without yellow stripes) is the grounding wire. Check with a qualified electrician if you don't completely understand these grounding instructions, or if you are not sure whether the machine is properly grounded. **DO NOT MODIFY** the plug provided: if it won't fit the outlet, have a proper outlet installed by a qualified electrician.

Extension Cords

Avoid using extension cords. If an extension cord is unavoidable, consult a qualified electrician to determine what type of extension cord will satisfy the grounding, current capacity, and other requirements of the particular situation.

MBB-5-C EXP

Must be installed by qualified electrician in compliance with the hazardous environment the mixing is taking place in. Consult electrician for timer options. Have flexible conduit attached to motor to allow motor freedom for belt adjustment.

Do not wire explosion proof equipment with plug and cord, as this should be wired direct in accordance with U.S. Underwriters' Class 1, Group D specifications.

When connecting motor to line, either rotation is permissible.



Operation

Safety Precautions

1. Make sure can lids are tightly closed.
2. Do not mix breakable containers such as glass, porcelain, etc.
3. Ensure container is securely clamped.
4. All customers should be kept away from the work area.
5. The mixer should be operated by trained personnel only.

Mixing Procedure

1. Insert can in cradle and center it.
2. Bring the aluminum crossbars to the top and bottom of the can.
3. Tighten the wing nuts equally, insuring that the aluminum crossbars stay flat against the surface of the can.
4. Turn mixer on. The required time to mix latex or enamel material is approximately 2 to 3 minutes per gallon.

Maintenance Procedures

Always disconnect machine from power source before maintaining or servicing.

Cleaning:

Keep the machine clean. Colorant or paint spilled on the machine can be cleaned with warm soapy water. After washing, oil the 5/8" threaded rods with 3in1 oil. Be careful not to get the timer wet.

Lubrication:

Oil capacity is one pint - do not exceed. Oil level to be maintained is determined from the marking on the oil gauge. Use number SAE 30 oil.

Keep the 5/8" threaded rods free of dirt, dried paint, and other materials. **Once a week apply a thin film of 3in1 oil to the 5/8" threaded rods.**

Belt Adjustment:

The belt adjustment screw is located on the base next to the drive housing. Belt should be tightened if belt starts to squeal or machine mixing speed is noticeably slower. Loosen jam nut and turn adjustment screw clockwise one turn at a time until mixer runs properly, tighten jam nut. Do not over-tighten belt which will put strain on belt and motor bearing.

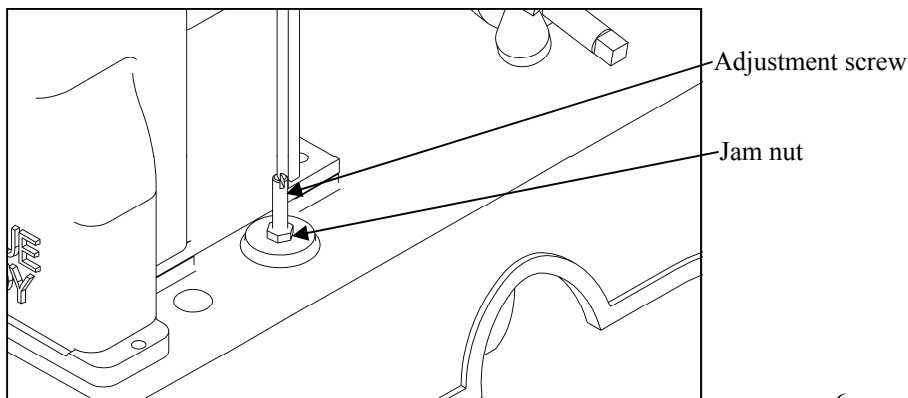

Drive Housing Assembly

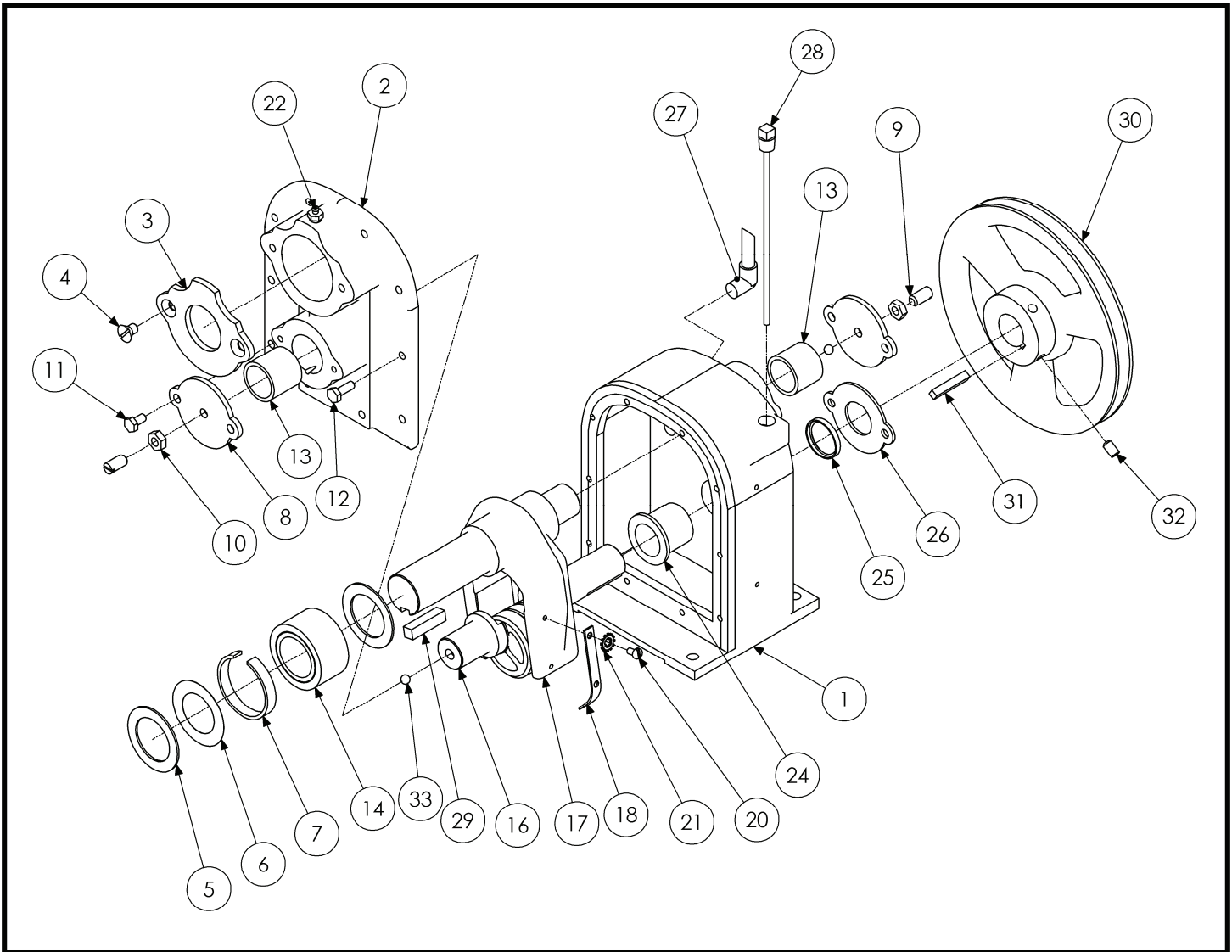

Item	Qty.	Part Number / Description	Item	Qty.	Part Number / Description
1	1	BB-2 Drive housing	17	1	BB-4 Fork rod
2	1	BB-3 Drive housing cover	18	1	Oil splasher
3	1	Front upper cover	20	2	Screw, pan head slotted 10-32 x .375
4	2	Screw, flat head slotted 5/16-18 x .50	21	2	Lock washer, int / ext tooth #10
5	2	Flat washer, 1.53ID x 2.25OD x .07thk	22	1	Grease zerk
6	1	Plastic diaphragm	24	1	Bronze flange bearing
7	1	Spacer	25	1	Oil seal
8	2	Front lower / rear upper cover	26	1	Rear lower cover
9	2	Set screw, slotted cup point 3/8-16 x .75	27	1	Vent
10	2	Nut, hex jam 3/8-16	28	1	Oil gauge
11	6	Screw, hex head cap 1/4-20 x .50	29	1	Square key 3/8" x 1.50L
12	10	Screw, hex head cap 1/4-20 x .75	30	1	BB-13 Drive pulley 8"
13	2	BB-20 Bronze bearing	31	1	Square key 1/4" x 1.50L
14	1	BB-21 Roller bearing	32	2	Set screw, knurl cup point 5/16-18 x .50
16	1	BB-5 Eccentric shaft	33	2	5/16" ball bearing
					BB-15 V-belt No. 2340 explosion proof
					No. 2333 Non -xproof

Clamp / Cradle Assembly

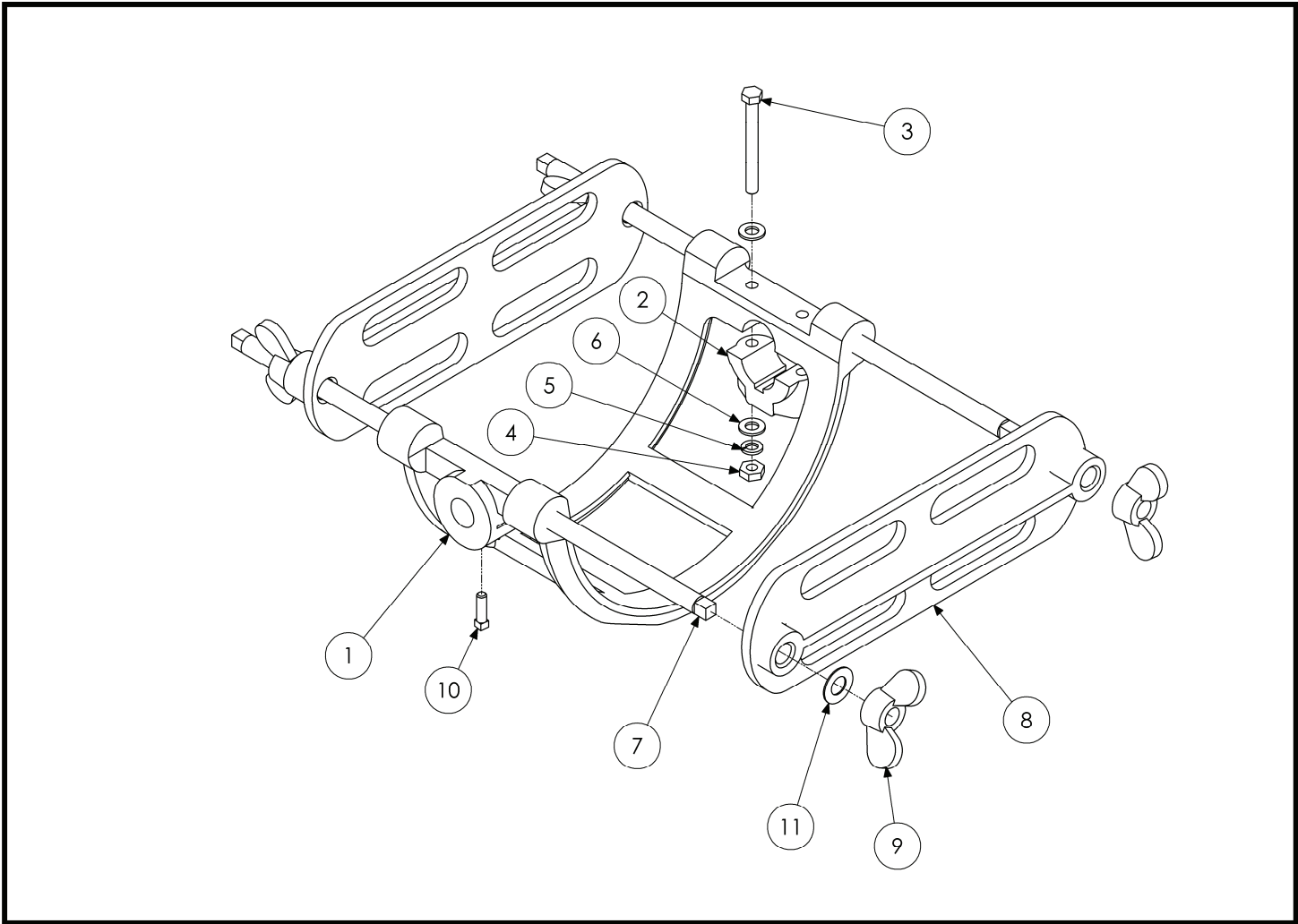

Item	Qty.	Part Number / Description
1	1	BB-9A Cradle
2	1	BB-9B Cradle half keyed
3	2	Screw, hex head cap 3/8-24 x 3.50
4	2	Nut, hex 3/8x24
5	2	Lock washer, 3/8" split
6	2	Flat washer, 3/8"
7	4	BB-10A 5/8" threaded rod
8	2	BB-12B Aluminum cross bar
9	4	BB-11A 5/8" wing nut
10	1	Set screw, square head 5/16-18 x 1.00
11	4	Thrust washer

Motor Drive Assembly (X-proof shown)

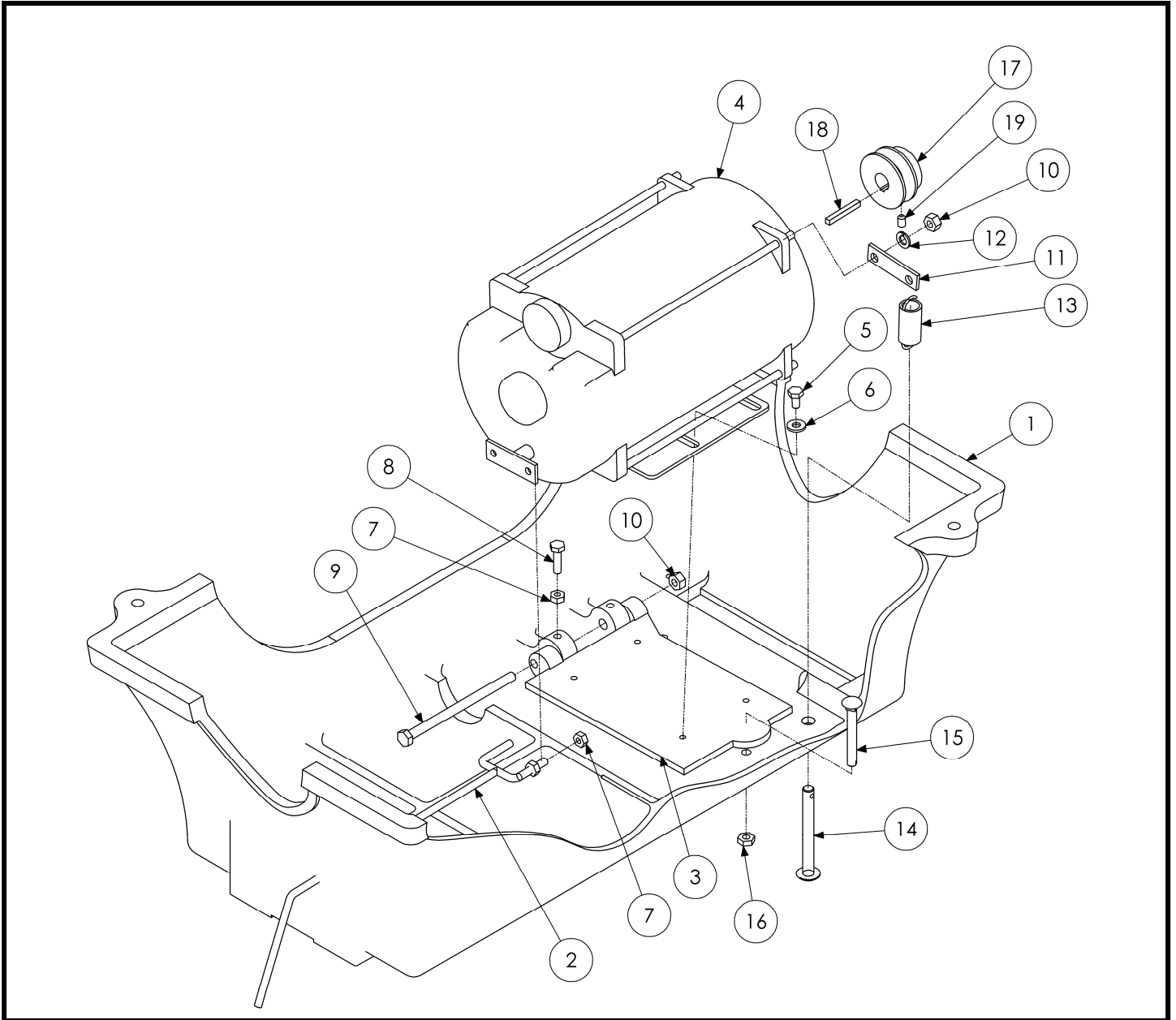

Item	Qty.	Part Number / Description
1	1	BB-1 Blue Boy base
2	1	On/Off lever (x-proof only)
3	1	BB-22 Motor base
4	1	Motor
5	4	Screw, hex head cap 1/4-20 x .50
6	4	Flat washer, 1/4"
7	4	Nut, hex 1/4-20
8	2	Screw, hex head cap 1/4-20 x 1.00
9	1	Screw, hex head cap 5/16-18 x 5.00
10	2	Nut, hex 5/16-18
11	1	Spring lever
12	1	Lock washer, 5/16" split
13	1	Extension spring

Item	Qty.	Part Number / Description
14	1	Custom carriage bolt
15	1	BB-22A Motor base bolt
16	1	Nut, hex jam 5/16-18
17	1	BB-14 Drive pulley, 2"
18	1	Square key, 3/16 x 1.50L
19	2	Set screw, knurl cup point 1/4-20 x .375

Base Assembly

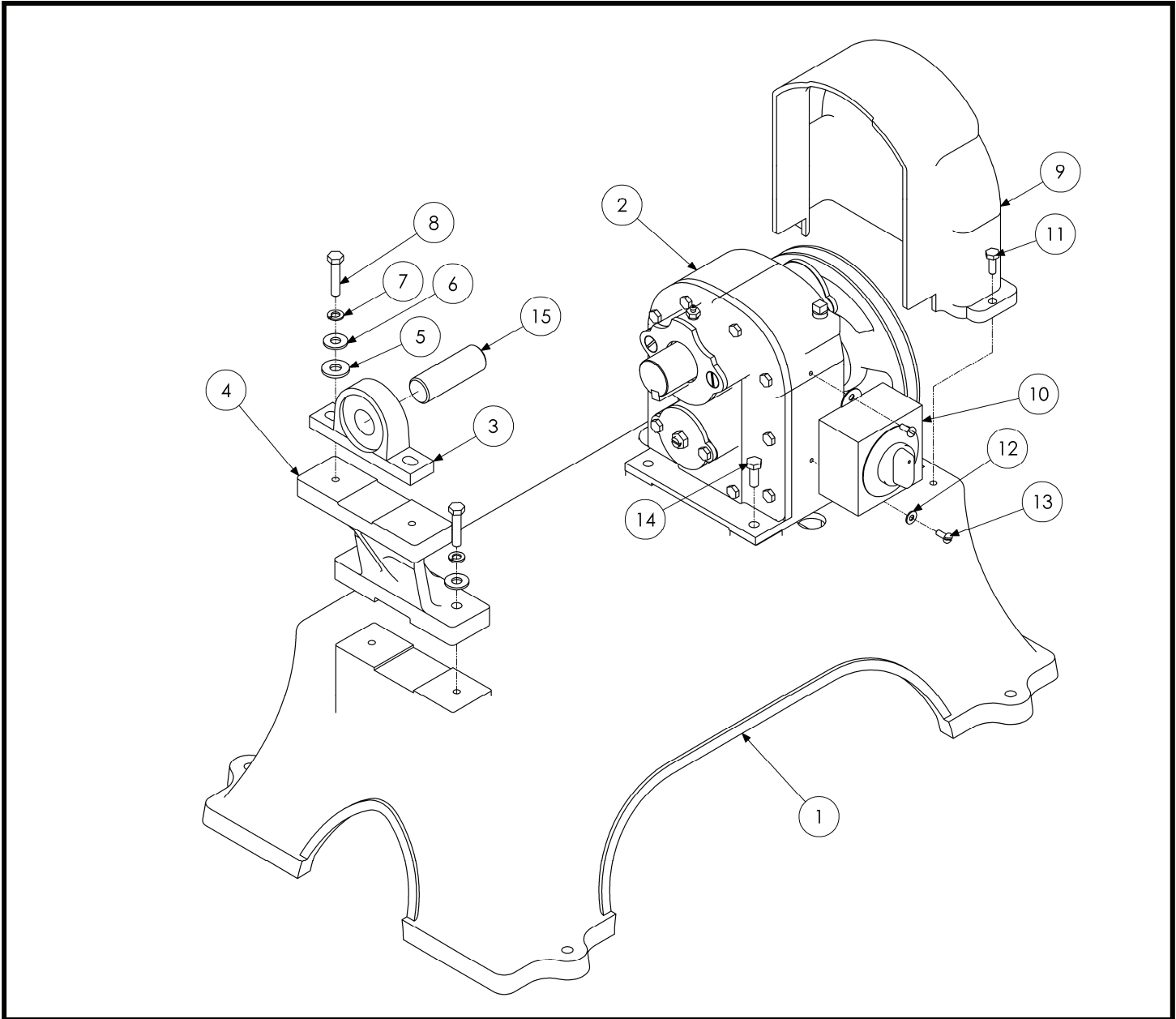

Item	Qty.	Part Number / Description
1	1	BB-1 Blue Boy base
2	1	Drive housing assembly
3	1	BB-7A 1" pillow block bearing
4	1	BB-6A Rear standard
5	2	Flat washer, 3/8"
6	4	Flat washer, 5/16"
7	4	Lock washer, 5/16" split
8	4	Screw, hex head cap 5/16-18 x 1.50
9	1	BB-16 Belt guard

Item	Qty.	Part Number / Description
10	1	Timer assembly
11	2	Screw, hex head 1/4-20 x .75
12	1	Flat washer, #10
13	2	Screw, pan head slotted 10-24 x .50
14	4	Screw, hex head cap 5/16-18 x 7/8
15	1	1.00" shaft

Timer Assembly (non-xproof only)

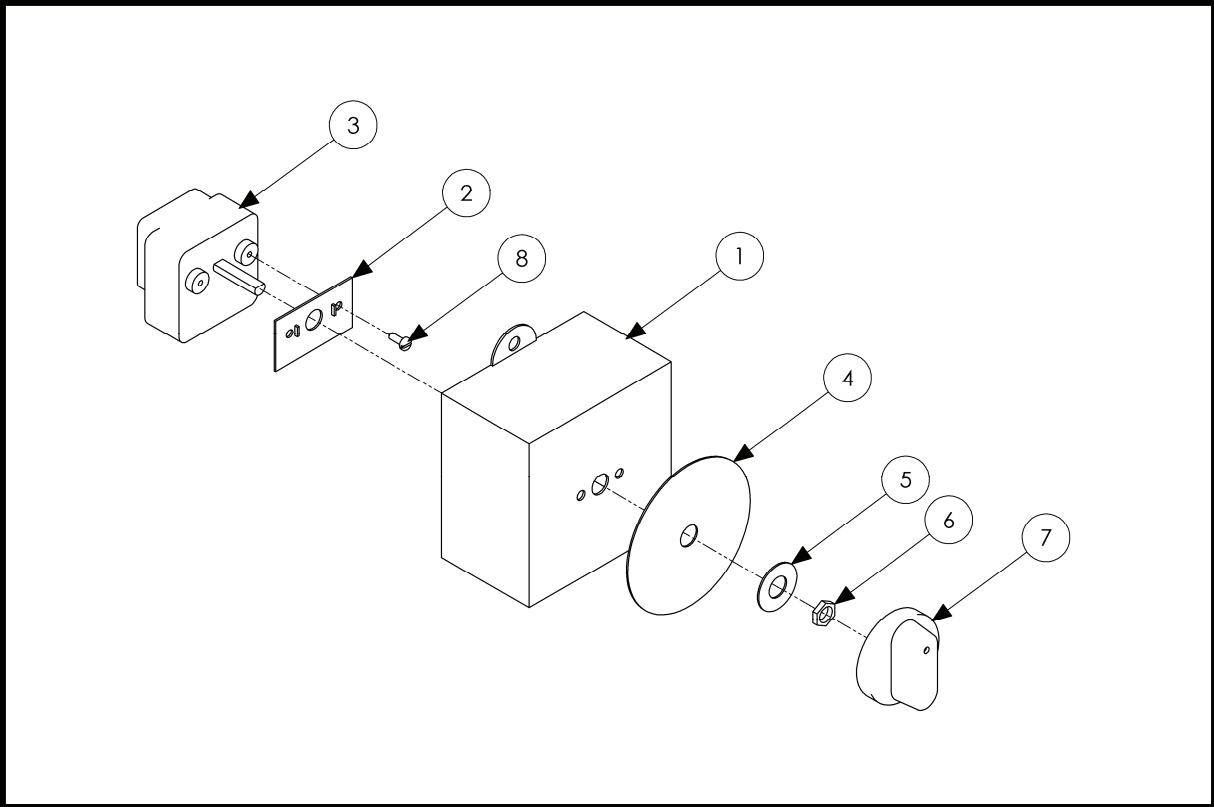

Item	Qty.	Part Number / Description
1	1	BB-19 Timer housing
2	1	Timer backing plate
3	1	BB-18 Timer 1 - 30 minute
4	1	Timer face plate
5	1	Timer washer
6	1	Timer nut
7	1	Timer knob
8	2	Screw, pan head slotted self tap 4-24 x 5/16



Ordering Replacement Parts

Contact our Customer Service Department at:

Miracle Paint Rejuvenator Company
 6160 Claude Way East
 Inver Grove Heights, Minnesota 55076

Ph: 651-222-1900 or 888-236-1143
 Fax: 651-222-8549

Warranty: 1 year parts & labor