

**Pacer Dual & Pacer Single Arm Mixers
Owner's Manual**



Table of Contents

Introduction.....	3
Safety Precautions.....	4
Installation Instructions.....	5
Electrical Connections.....	7
Operating Instructions.....	8
Air-driven models.....	9
Troubleshooting.....	10
Wiring Diagrams.....	11
Parts list.....	12
Ordering Replacement Parts..	18



Introduction

The PACER INDUSTRIAL MIXERS Dual arm and Single arm mixers are heavy duty quality built machines that offer dependable operation throughout their lifetime.

To take full advantage of your mixer's capabilities, you should understand its features and proper operation. Before operating mixer read this manual completely and save for future reference.

Machine Models

This manual includes instructions and replacement parts information on all models PACER INDUSTRIAL MIXERS Dual arm and Single arm mixers.

- 110V 60 Hz mixers.
- Mounting bases: Counter-stand, Floor-stand.
- Clamp safety covers.
 - Left arm safety cover for Single arm mixers.
 - Left and right arm safety covers for Dual arm mixers.
- Standard and explosion proof.
- 15 min., 30 min. and 60 min. dial timers. 6 minute pushbutton timer. Explosion proof model: no timer.

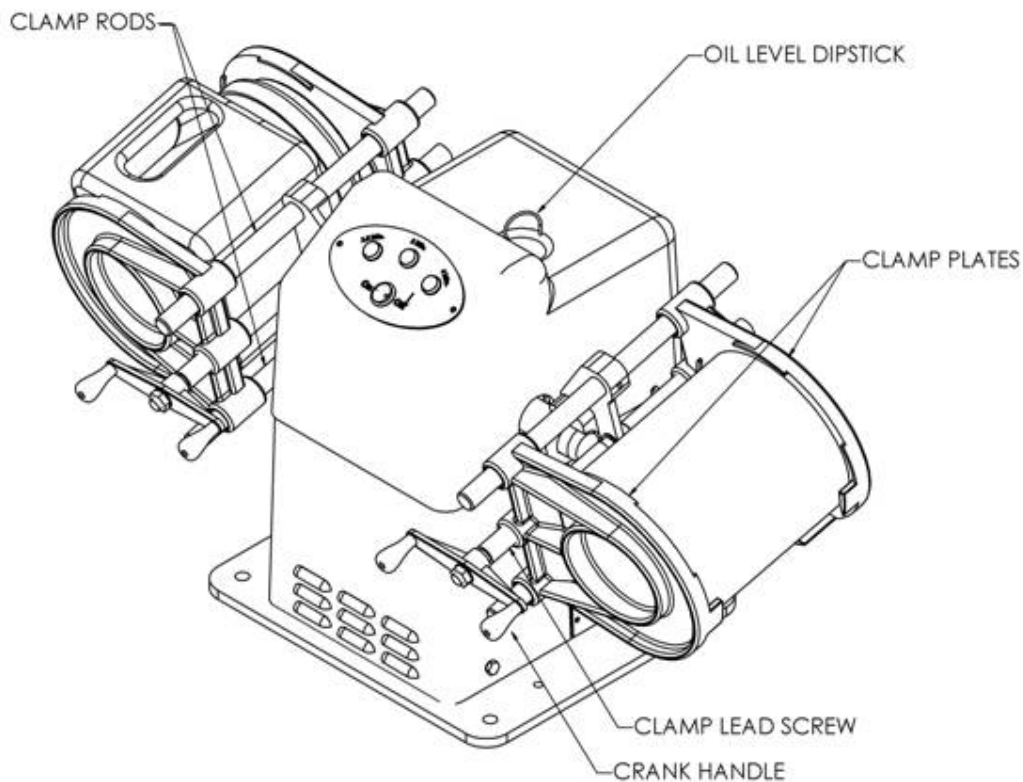



Safety Precautions

Follow these safety precautions when operating the PACER INDUSTRIAL MIXERS Dual arm or Single arm mixers.

Installation

1. Before operating the machine, read this Owner's manual carefully.
2. Ground the machine properly. Be sure to follow proper grounding and electrical procedures.
3. Avoid dangerous environments. Do not use the machine in a damp or wet environment.
4. Use the proper power source. Refer to the machines designation label located on the back of the machine. If it is unreadable call our customer service department (1-888-236-1143) before connection the mixer to a power source.
5. Avoid extension cords. To minimize the risk of circuit overload, or improper electrical grounding do not use extension cords.

Operation

6. Ensure the can being mixed is securely clamped.
7. Keep customers away from mixing area. Only trained personnel should operate the mixer.

Maintenance

8. Do not get the timer, control panel or wiring wet. Failure to do so could result in electric shock.
9. Clean all surfaces of the machine with soap and water. Do not use any solvent-based cleaners or thinners.
10. Disconnect machine from power source before cleaning or servicing mixer.
11. Be sure to maintain the mixer on a regular basis. Follow the maintenance procedures on page 7.

SAFETY INSTRUCTIONS

- Review Owner's Manual before operating.
- Ensure container is securely clamped.
- Use of clamp safety covers are recommended.
- Disconnect power source before servicing machine.



WARNING

EXPLOSION HAZARD



- Consult the Owners Manual before installing or operating.
- Do Not use in hazardous environment where dust or flammable vapors are present.
- Do Not mix flammable materials or materials with a low flashpoint per the material safety data sheet.



Installation Instructions

The PACER INDUSTRIAL MIXERS Dual arm and Single arm mixers are shipped fully assembled. The machine must be mounted to the PACER INDUSTRIAL MIXERS Floor Stand or Counter Stand. Failure to do so will void the warranty. Refer to the instructions below.

Remove the dipstick holder cap at the top of the mixer, and insert the dipstick in its place. Failure to do so will cause oil leakage and void the warranty.

Installing the mixer on the Counter Stand.

1. Assemble the Counter Stand castings to the mixer using the hardware provided.
2. Insert a rubber foot into the top and bottom of each spring.
3. Insert a spring and foot assembly into the recess in the bottom of each corner of the Counter Stand castings.
4. Plug the power cord into a grounded receptacle (see page 7).

Note: Explosion proof models are not furnished with a power cord. The machine must be hard wired to the power source by a qualified electrician.

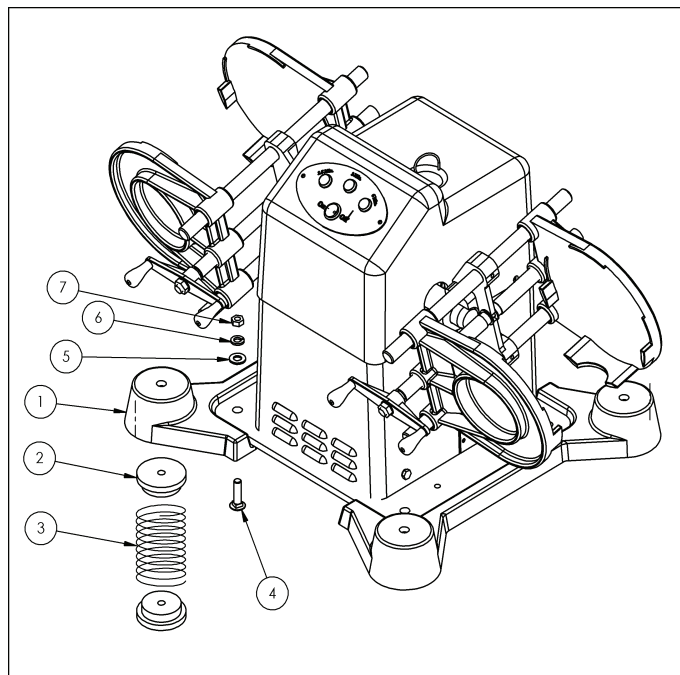

Item	Qty.	Part Number / Description
1	2	PIM-00060 Counter stand casting
2	8	PIM-10063 Rubber bumper
3	4	PIM-10064 Spring
4	4	PIM-10114 Carriage bolt, 3/8-16 x 1.50
5	4	PIM-10119 Flat washer, 3/8
6	4	PIM-10172 Lock washer, split 3/8
7	4	PIM-10127 Nut, hex 3/8-16

Installing the mixer on the Floor Stand.

1. Assemble (8) suction cups to the bottom of the floor stand using the hardware provided.
2. Assemble the mixer and (4) isolators (provided with the mixer) to the Floor Stand using the hardware provided.
3. Plug the power cord into a grounded receptacle (see page 7).

Note: Explosion proof models are not furnished with a power cord. The machine must be hard wired to the power source by a qualified electrician.

4. If the suction cups do not grip the floor properly the base may creep while the mixer is operating. If this does occur, anchor the base to the floor with rubber cement:
 - A. Tilt the mixer and floor stand until you can fit two 2" x 4" boards under the floor stand. This will lift the suction cups far enough off the floor to apply rubber cement. Make sure the boards do not touch the suction cups.
 - B. Clean the floor directly under the suction cups. Clean the contacting surface of the suction cups.
 - C. Apply rubber cement to the contacting surface of the suction cups and the floor directly under the suction cups.
 - D. Allow the rubber cement to dry until it becomes tacky. Remove the boards and lower the floor stand to the floor.
 - E. Allow the rubber cement to dry overnight before running the mixer.

If you ever need to move the mixer, you can break the bond by inserting a wall scraper between the suction cup and the floor.

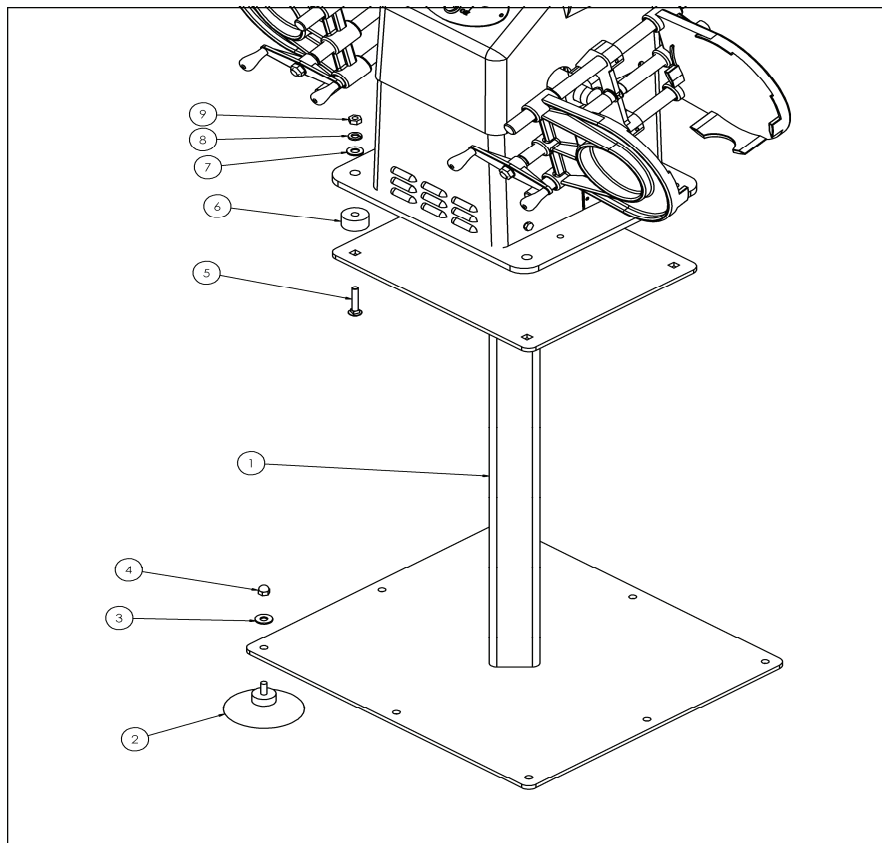

Item	Qty.	Part Number / Description	Item	Qty.	Part Number / Description
1	1	PIM-10108 Floor stand	6	4	PIM-10049 Isolator
2	8	PIM-10069 Suction cup	7	4	PIM-10119 Flat washer, 3/8
3	8	PIM-10120 Flat washer, 5/16	8	4	PIM-10172 Lock washer, split 3/8
4	8	PIM-10126 Acorn nut, 5/16-18	9	4	PIM-10127 Nut, hex 3/8-16
5	4	PIM-10115 Carriage bolt, 3/8-16 x 2.50			



Electrical Connection and Grounding Requirements

⚠ WARNING

**RISK OF ELECTRIC SHOCK.
ALWAYS HAVE MACHINE PROPERLY
GROUNDED.**

Your mixer **MUST BE PROPERLY GROUNDED**. If there is an electrical short circuit, grounding reduces the risk of electric shock.

The machine's power cord has a grounded plug. This plug must be inserted into an electrical outlet that is properly installed and grounded according to all local codes and ordinances.

If you must repair or replace the power cord or plug, do not connect the grounding wire to either flat-blade terminal. The wire with insulation having an outer surface that is green (with or without yellow stripes) is the grounding wire. Check with a qualified electrician if you don't completely understand these grounding instructions, or if you are not sure whether the machine is properly grounded. **DO NOT MODIFY** the plug provided: if it won't fit the outlet, have a proper outlet installed by a qualified electrician.

Extension Cords

Avoid using extension cords. If an extension cord is unavoidable, consult a qualified electrician to determine what type of extension cord will satisfy the grounding, current capacity, and other requirements of the particular situation.



Operation

Safety Precautions

1. Before operating the machine, read this Owner's manual carefully. **For special air-driven model instructions see page 9.**
2. Ground the machine properly. Be sure to follow proper electrical connection and grounding requirement procedures.
3. Non-explosion proof models only: **Do not use in hazardous environment where dust or flammable vapors are present. Do not mix flammable materials or materials with a low flashpoint per the material safety data sheet.**
4. Make sure can lids are tightly closed.
5. Do not mix breakable containers such as glass, porcelain, etc.
6. Ensure container is securely clamped.
7. All customers should be kept away from the work area.
8. The mixer should be operated by trained personnel only.

NOTE: The motor is protected by a thermal overload cutoff switch. If the temperature of the motor gets too hot it will automatically shut off. The motor will not start again until it has cooled down.

Mixing Procedure

1. Turn the clamp handle counter-clockwise to open the clamp.
2. Place the container to be mixed in the clamp and turn the clamp handle clockwise until the container is secured.
3. If mixing only one container on a dual mixer clamp an empty can (or a piece of 2" x 4" board) in the other clamp.
4. After the containers are secured, set the timer for desired mix time.
5. The mixer will turn off after the mix time has elapsed.

Maintenance Procedures

Always disconnect machine from power source before maintaining or servicing.

Cleaning:

Keep the machine clean. Colorant or paint spilled on the machine can be cleaned with warm soapy water and/or mineral spirits. After washing, oil the clamp rods and clamp lead screw to prevent rusting. Be careful not to get the control panel or timer wet.

Lubrication:

Measure the oil level. It should register between the two marks on the dip stick. If oil is needed use an SAE 10W30 motor oil, do not overfill.

Keep the clamp rods and clamp lead screw free of dirt, dried paint, and other materials. Remove any small nicks with a fine file. **Once a week apply a thin film of oil to the clamp rods and clamp screw.**



Air-Driven Model

The Instructions in this manual apply to both electrically powered and air driven models, with the exceptions noted below.

Installation

Air Supply

Fill the Lubricator reservoir with an SAE-10W motor oil.

Connect a 10-cfm air supply to the inlet side of the ball valve and filter on the front of the mixer.

The regulator is factory set at 100psi.

The air supply must be at least 100psi to reliably operate the machine, and **must not exceed 200psi**.

Air driven models require no electrical connection.

Operation

Mixing Procedure

Air-driven models don't have a timer. Control the mixing time by turning the air supply on and off.

Flammable materials may be mixed in air-driven models.

Maintenance

Cleaning

In addition to cleaning instructions on page 8, replace the air filter element when dirty. Replacement filter elements are available from you local Aro pneumatic supplies dealer.

Parts

PIM-10231 Air motor

PIM-10232 Filter / Lubricator





Troubleshooting

PROBLEM	CAUSE	SOLUTION
Mixer won't operate.	Power cord unplugged.	Plug in power cord.
	Motor thermal overload tripped.	Allow motor to cool.
	Building circuit breaker or fuse blown.	Reset breaker or replace fuse.
	Faulty timer.	Have a qualified electrician replace timer.
	Broken, worn or loose drive belt.	Visually inspect drive belt and replace if necessary.
Clamp doesn't hold can securely.	Worn or damaged clamp plate.	Replace clamp plate.
Clamp binds when turning clamp handle.	Clamp lead screw and/or clamp rods need to be lubricated.	Apply a thin film of oil to clamp screw and clamp rods.
	Worn or damaged clamp plate.	Replace clamp plate.
Mixer doesn't shut off at end of mixing cycle.	Faulty timer.	Have a qualified electrician replace timer.
Mixer is unbalanced.	Clamps are not positioned properly in relation to the counterweight on pulley.	With the clamps in a horizontal position, counterweight on pulley should be in the 9 o'clock position.

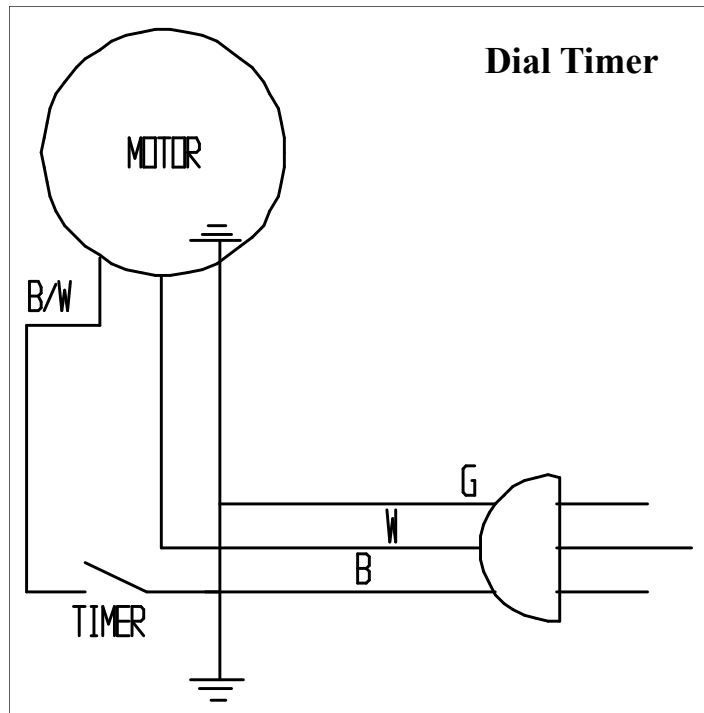
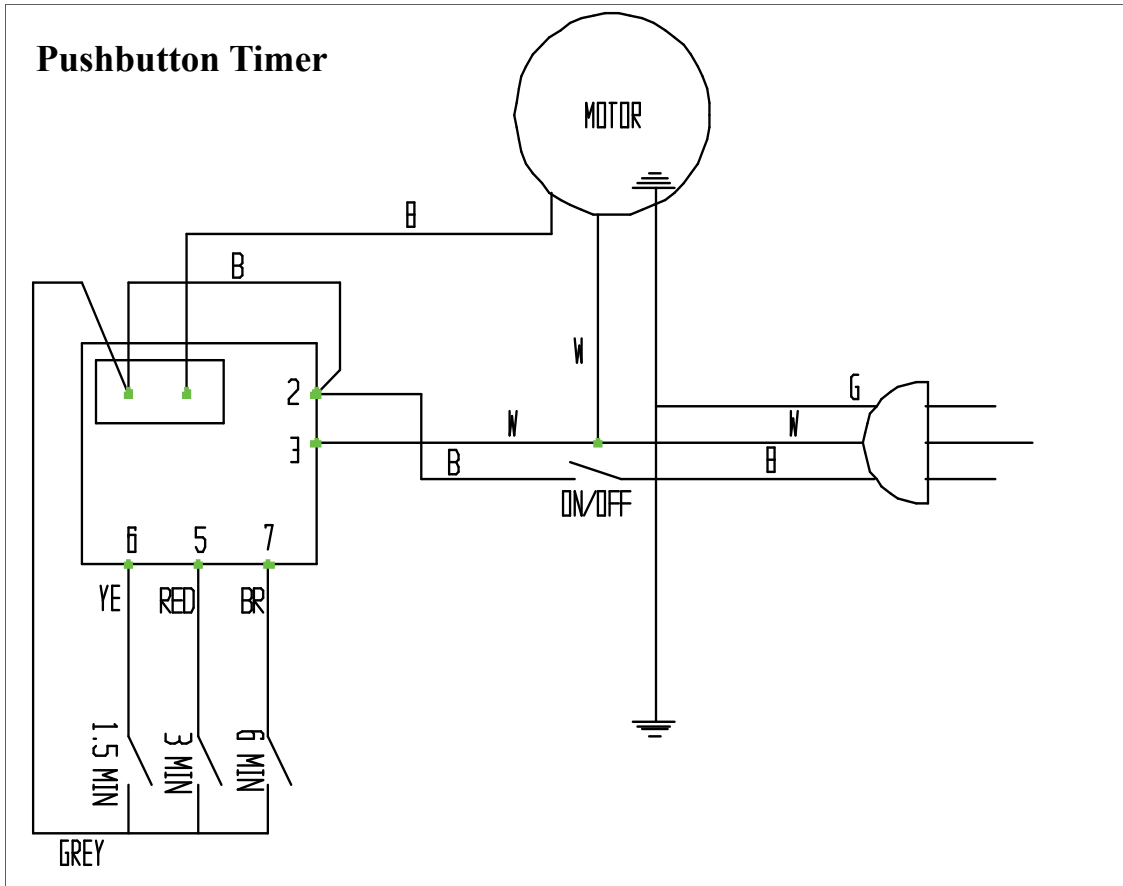

Bearing Housing Assembly

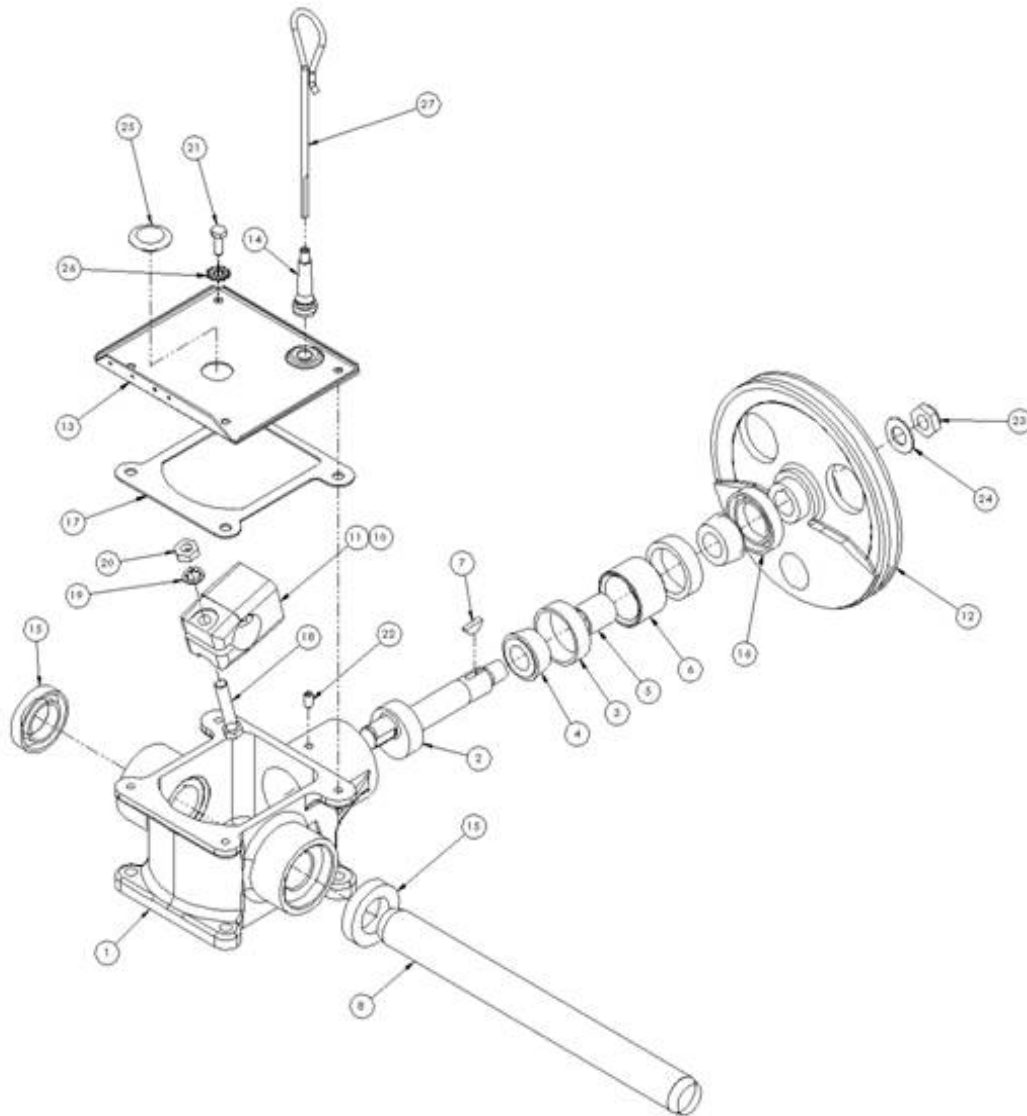

Item	Qty.	Part Number / Description	Item	Qty.	Part Number / Description
1	1	PIM-10000 Bearing housing	15	2	PIM-10007 Side seal
2	1	PIM-10004 Camshaft	16	1	PIM-10008 Front seal
3	2	PIM-10014 Bearing cup	17	1	PIM-10012 Gasket
4	2	PIM-10013 Bearing cone	18	1	PIM-10145 Hex head screw 3/8 - 24 x 2.00
5	1	PIM-10002 Small spacer	19	1	PIM-10123 Internal tooth lockwasher 3/8
6	1	PIM-10001 Large spacer	20	1	PIM-10128 Hex nut 3/8-24
7	1	PIM-10158 Woodruff key #606	21	4	PIM-10141 Hex head screw 1/4-20 x .75
8	1	PIM-10006 Main shaft	22	1	PIM-10155 Set screw 1/4 - 20 x .50
10	1	PIM-10009 Spherical bearing	23	1	PIM-10130 Nylock jam nut 5/8-16
11	1	PIM-10005 Connector block	24	1	PIM-10121 Flat washer .63 ID, 1.205 OD
12	1	PIM-10003 Counterweight pulley	25	1	PIM-10010 Cap plug
13	1	PIM-10110 Bearing housing cover	26	4	PIM-10122 Lockwasher, int / ext tooth 1/4
14	1	PIM-10011 Dipstick holder	27	1	PIM-10161 Dipstick

Clamp Assemblies

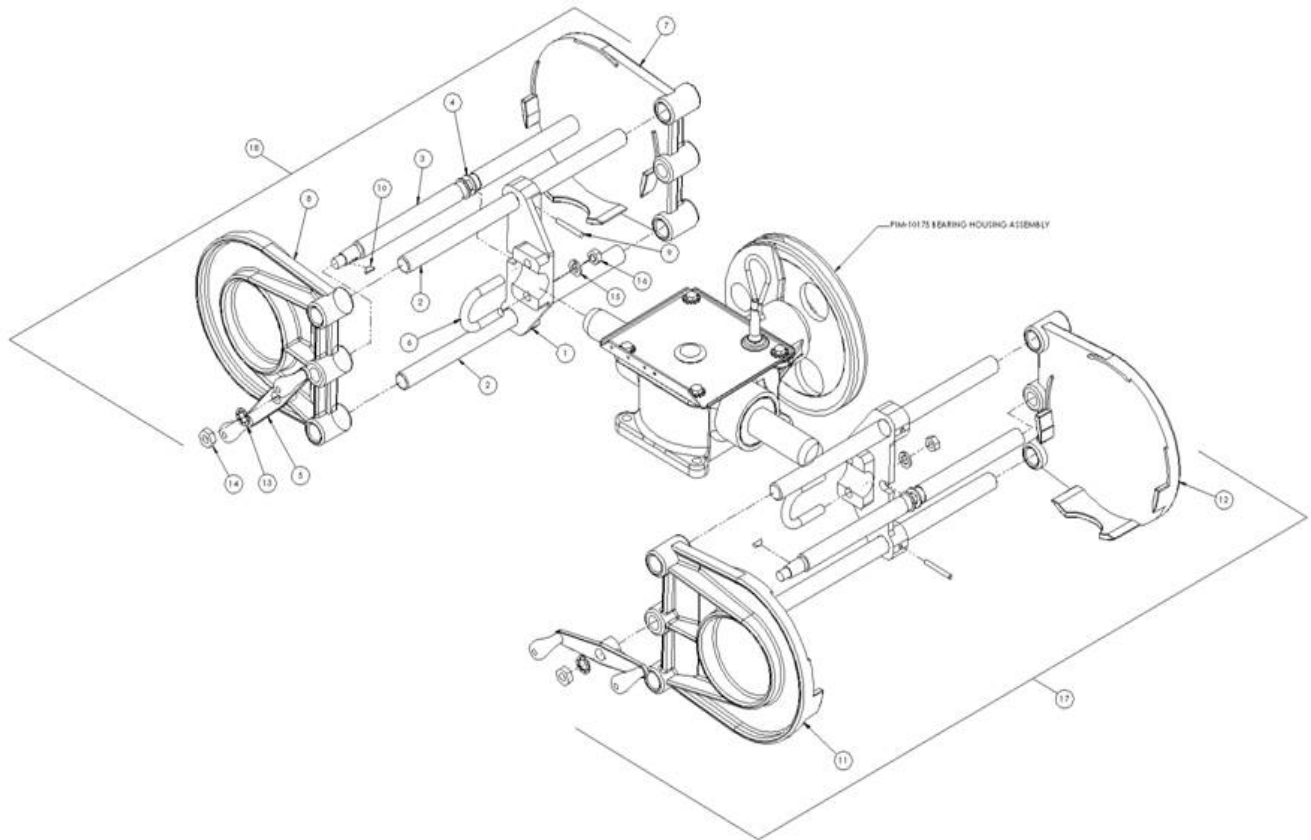

<u>Item</u>	<u>Qty.</u>	<u>Part Number / Description</u>	<u>Item</u>	<u>Qty.</u>	<u>Part Number / Description</u>
1	2	PIM-10016 Clamp rod holder	10	2	PIM-10157 #404 Woodruff key
2	4	PIM-10017 Clamp rod	11	1	PIM-10024 Clamp plate, right front
3	2	PIM-10019 Clamp lead screw	12	1	PIM-10025 Clamp plate, right rear
4	4	PIM-10021 Thrust bearing	13	2	PIM-10124 Lockwasher, internal tooth 7/16
5	2	PIM-10023 Crank handle	14	2	PIM-10129 Nut, hex jam 7/16-20
6	2	PIM-10022 U-bolt	15	4	PIM-10172 Lockwasher, split 3/8
7	1	PIM-10020 Clamp plate, left rear	16	4	PIM-10127 Nut, hex 3/8-16
8	1	PIM-10111 Clamp plate, left front	17	1	PIM-10173 Right clamp assembly (Dual arm mixer only).
9	5	PIM-10018 Rollpin, 3/16 x 1.50	18	1	PIM-10174 Left clamp assembly (Single arm & Dual arm mixers).

Drive Assembly

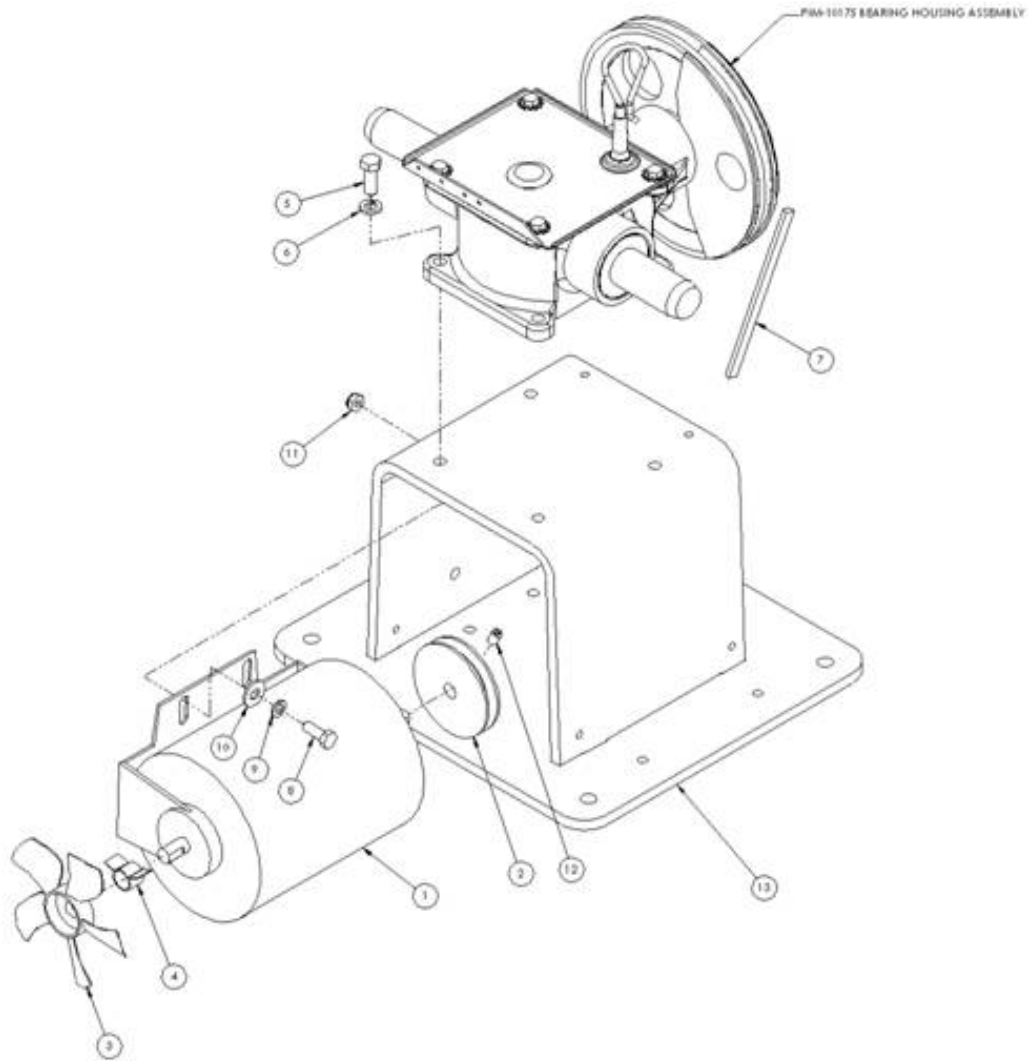

Item	Qty.	Part Number / Description
1	1	PIM-10029 Motor, 110V / 60Hz
2	1	PIM-10032 Motor pulley
3	1	PIM-10030 Motor fan
4	1	PIM-10031 Motor fan clip
5	4	PIM-10143 Screw, hex head cap 3/8-16 x 1.00
6	4	PIM-10172 Lockwasher, split 3/8
7	1	PIM-10033 Drive belt
8	4	PIM-10176 Screw, hex head cap 5/16-18 x 7/8
9	4	PIM-10125 Lockwasher, split 5/16
10	4	PIM-10120 Flat, washer 5/16 USS
11	4	PIM-10136 Nut, nylock jam 5/16-18
12	1	PIM-10177 Set screw, knurled cup point 5/16-18 x .50

Enclosure Assembly & Mechanical Timers

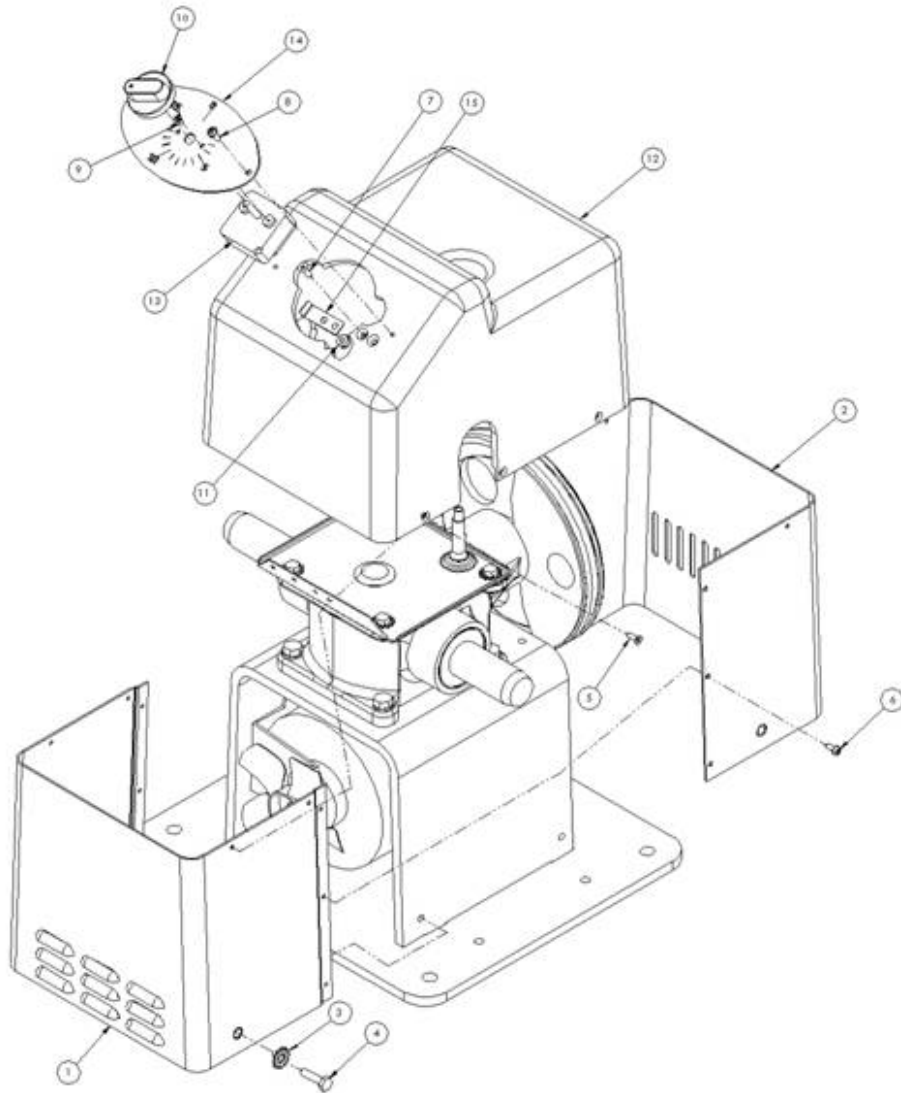

Item	Qty.	Part Number / Description	Item	Qty.	Part Number / Description
1	1	PIM-10041 Bottom enclosure, front	10	1	PIM-10036 Timer knob
2	1	PIM-10170 Bottom enclosure, back	11	2	PIM-10132 Nut, nylock 10-32
3	4	PIM-10122 Lockwasher, int / ext tooth 1/4	12	1	PIM-10045 Top enclosure
4	4	PIM-10169 Screw, hex head cap 1/4-20 x 1.00	13	1	PIM-10035 Timer, 15 minutes
5	6	PIM-10140 Screw, flat head self tapping #8 x .50	13	1	PIM-10163 Timer, 30 minutes
6	6	PIM-10171 Screw, pan head self tapping #8 x .25	13	1	PIM-10164 Timer, 60 minutes
7	2	PIM-10162 Screw, flat head #10-32 x .50	14	1	PIM-10037 Timer plate, 15 minutes
8	2	PIM-10154 Screw, pan head thread cutting #8-18 x .50	14	1	PIM-10165 Timer plate, 30 minutes
9	2	PIM-10181 Screw, pan head self tapping #4-24 X 5/16	14	1	PIM-10166 Timer plate, 60 minutes
			15	1	PIM-10180 Grounding strip

Pushbutton Timer Assembly

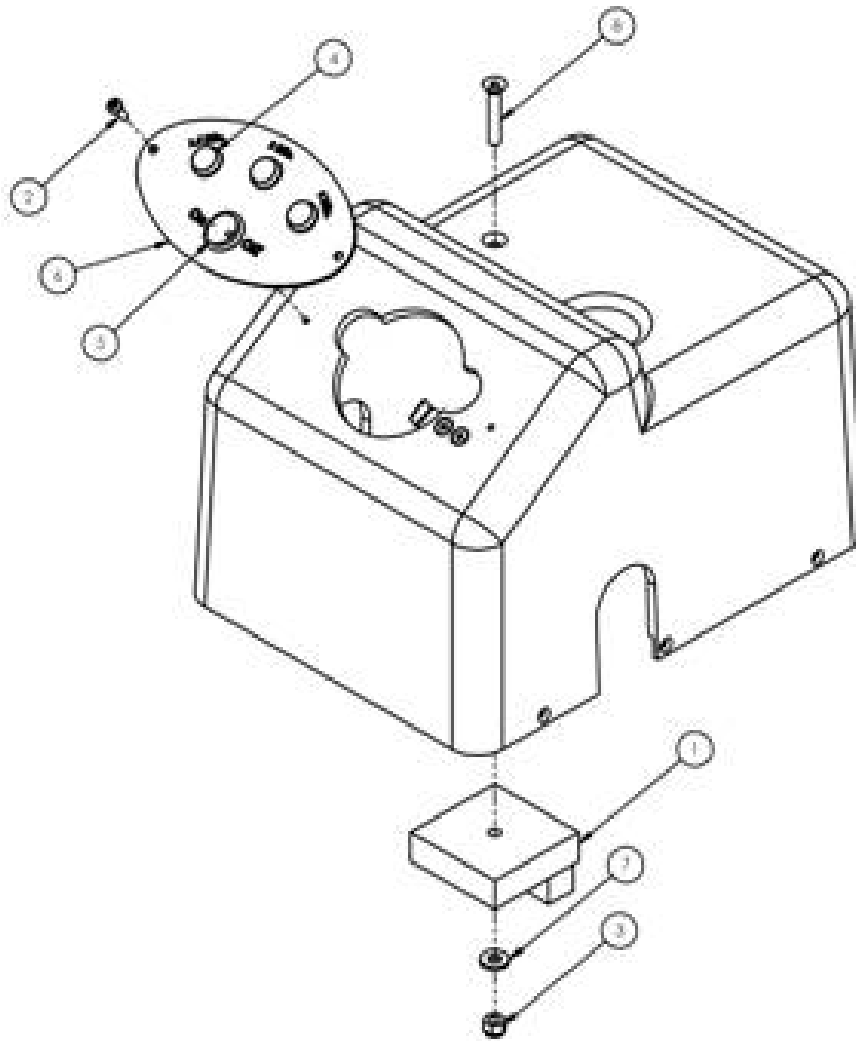

<u>Item</u>	<u>Qty.</u>	<u>Part Number / Description</u>
1	1	PIM-10184 Controller
2	2	PIM-10154 Screw, pan head thread cutting #8-18 x .50
3	1	PIM-10134 Nut, nylock 1/4-20
4	3	PIM-10182 Pushbutton
5	1	PIM-10183 On / off switch
6	1	PIM-10168 PB timer plate
7	1	PIM-10118 Flat washer, 1/4 SAE
8	1	PIM-10185 Screw, flat head socket 1/4-20 x 1.50

Explosion-Proof Assembly

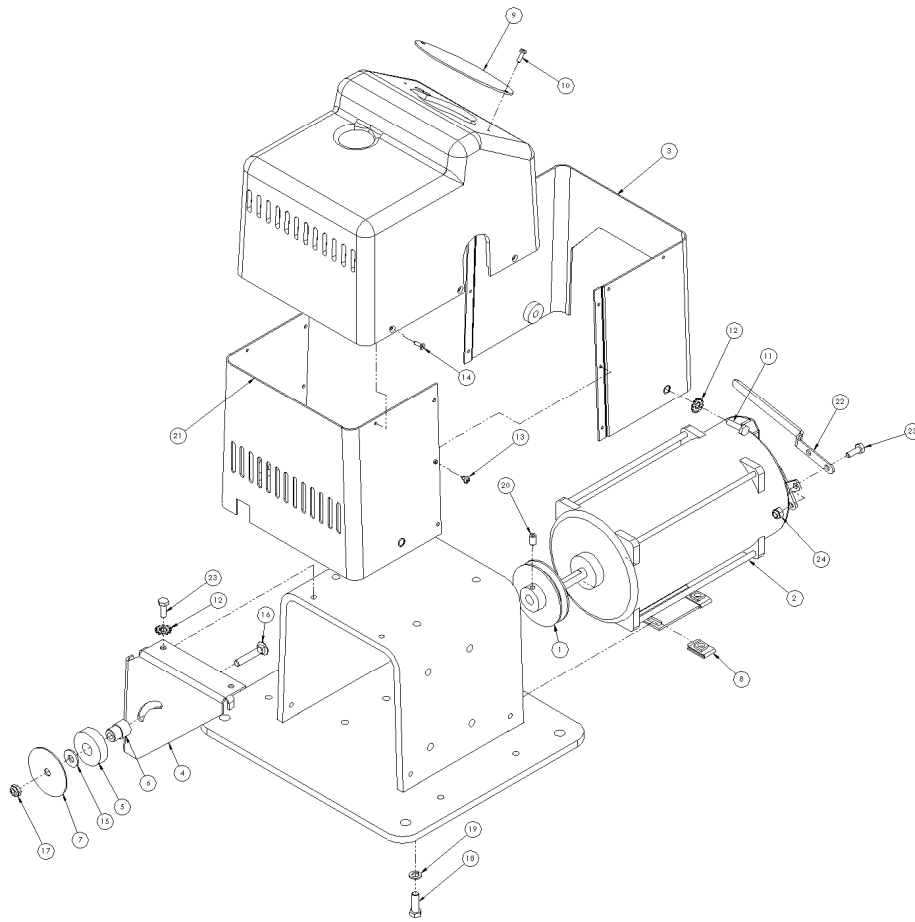

<u>Item</u>	<u>Qty.</u>	<u>Part Number / Description</u>	<u>Item</u>	<u>Qty.</u>	<u>Part Number / Description</u>
1	1	PIM-10032 Motor pulley	13	6	PIM-10171 Screw, pan head self tapping 8 x 5/16 type-AB
2	1	PIM-10075 Explosion proof motor	14	6	PIM-10140 Screw, flat head self tapping 8 x .50 type-AB
3	1	PIM-10072 Bottom-front enclosure, x-proof	15	1	PIM-10120 Flat washer, 5/16 uss
4	1	PIM-10076 Idler support	16	1	PIM-10116 Carriage bolt, 5/16-18 x 1.75
5	1	PIM-10109 Idler bearing	17	1	PIM-10136 Nut, nylock jam 5/16-18
6	1	PIM-10077 Idler bushing	18	4	PIM-10144 Screw, hex head cap 5/16-18 x 1.00
7	1	PIM-10117 Fender washer, 3/8 x 2.00 x .06 thick	19	4	PIM-10125 Lockwasher, split 5/16
8	4	PIM-10156 Tinnerman nut	20	1	PIM-10177 Set screw, knurled cup point 5/16-18 x .50
9	1	PIM-10187 Cover plate, x-proof	21	1	PIM-10043 Bottom enclosure, back
10	2	PIM-10154 Screw, pan head thread cutting 8-18 x .50 type-25	22	1	PIM-10188 On/off lever, x-proof
11	4	PIM-10169 Screw, hex head cap 1/4-20 x 1.00	23	4	PIM-10141 Screw, hex head cap 1/4-20 x .75
12	6	PIM-10122 Lockwasher, int-ext tooth 1/4	24	2	PIM-10134 Nut, nylock 1/4-20



Ordering Replacement Parts

Contact our Customer Service Department at:

Pacer Industrial Mixers
6160 Claude Way East
Inver Grove Heights, Minnesota 55076

Ph: 651-222-1900 or 888-236-1143
Fax: 651-222-8549